

油試驗用離心機 Oil Test Type



COD-1004 / COD-1008

■ 本機適用於測定燃油中水分及沉澱物或潤滑油中溶劑不溶物之用。

This machine can be applied to test the contents of water and other sediments in the oil or the insoluble ingredients in the lubricant.

特點：

- 數位式設定及顯示轉速、離心力以及時間。
- 10組記憶系統，可預先設定常用參數。
- 不平衡斷電、過載、故障指示安全防護裝置。

Feature :

- Digital RPM, RCF and Time setting & display
- 10 memory programs for presetting parameters
- With auto power-off safety devices included rotor imbalance, overload, and error indication

Model	COD-1004	COD-1008
轉速 Speed (rpm)	500~2,000	
最大離心力 Max. RCF (xg)	1,080	1,150
油測試瓶 Oil Test Bottle (pcs)	4	8
定時器 Timer (min:sec)	99:59	
重量 Weight (kg)	160	
尺寸 Size (W x L x H mm)	690 x 770 x 1040	
電源 Power	AC 110V / 220V, 50/60Hz	

◎ 離心試管另購。 Tubes not included.

■ Rotor sets for COD-1004, COD-1008

COD-1004



RS-100

Tube x 4



GT-1 / GT-2
GT-4 / GT-5



RS-104

Tube x 4



GT-3

COD-1008



RS-108

Tube x 8



GT-1 / GT-2
GT-4 / GT-5

JIS規格品

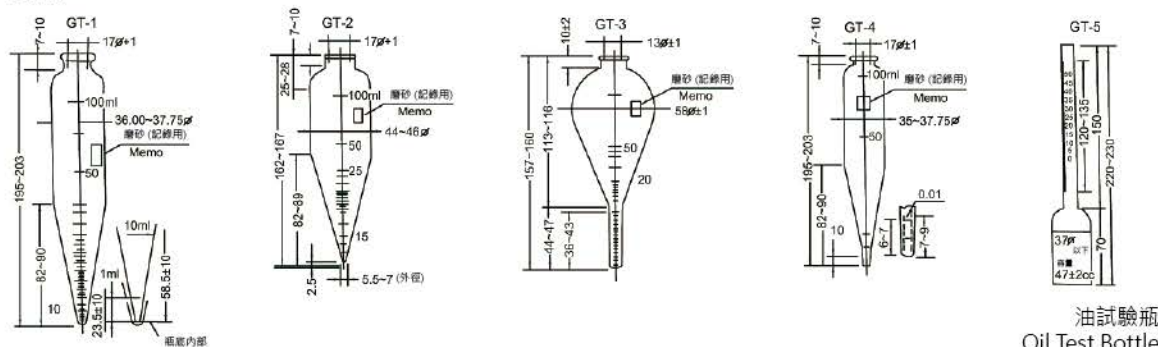

油試驗瓶
Oil Test Bottle

Rotor		Capacity (ml x pcs)	Tube Size (Ø x L) mm	Max. Speed (rpm)	Max. RCF (xg)
COD-1004	RS-100	請參考上圖 Refer to the above diagrammatic explanation.		2,000	1,080
	RS-104				890
COD-1008	RS-108				1,150